

PCB封装库的建立

对应物理器件

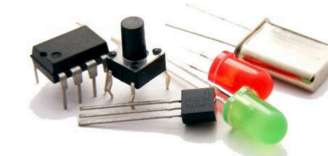

封装库 (Footprint) - 器件通过封装库的焊盘安装在PCB板上

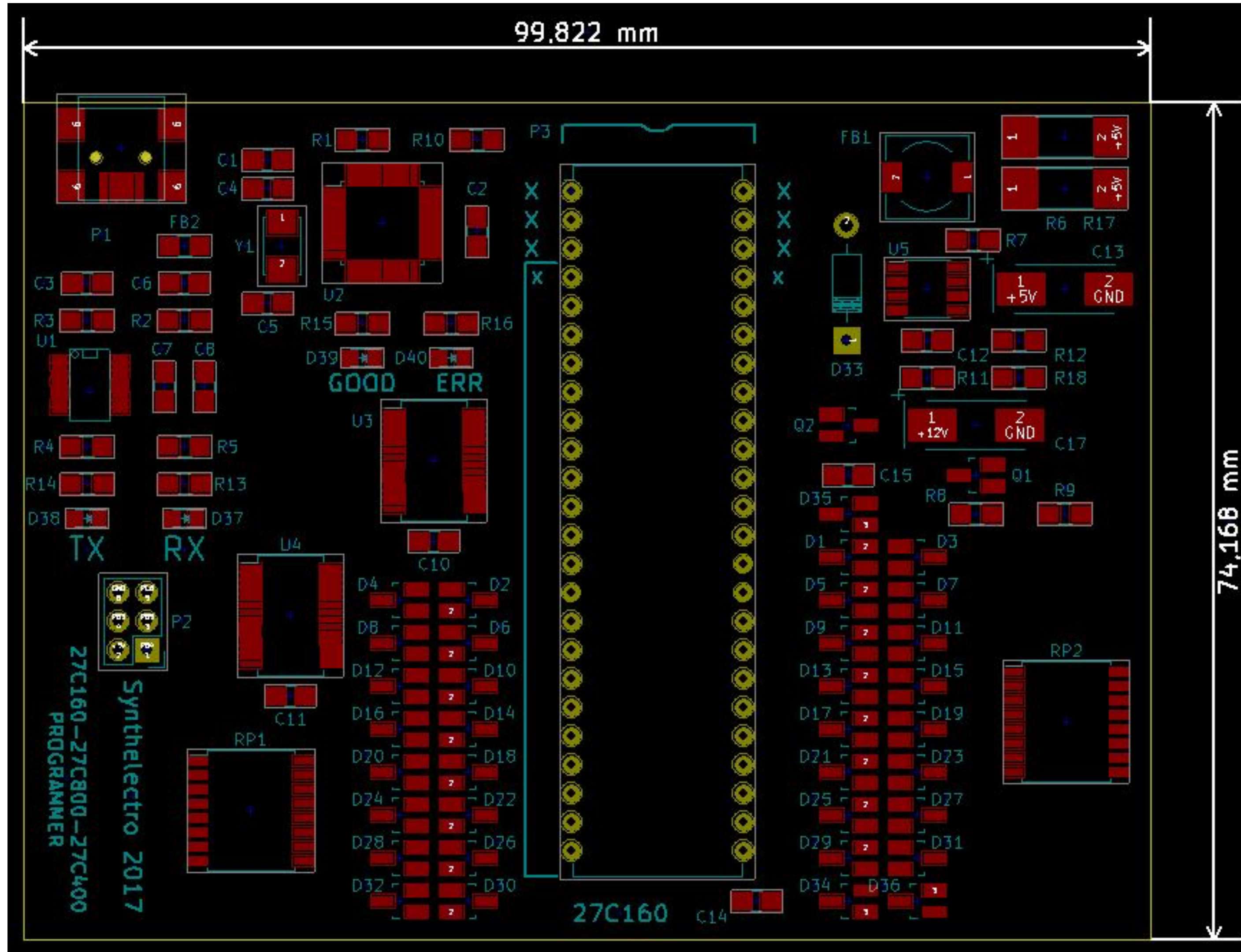

重要的事情再说一遍 - 建库要仔细!

- 严格参照元器件数据手册中的封装规格来建
- 与原理图要严格对应 - 封装的命名、管脚的编号
- 适合焊接、生产
- 打印出来跟实物对比验证

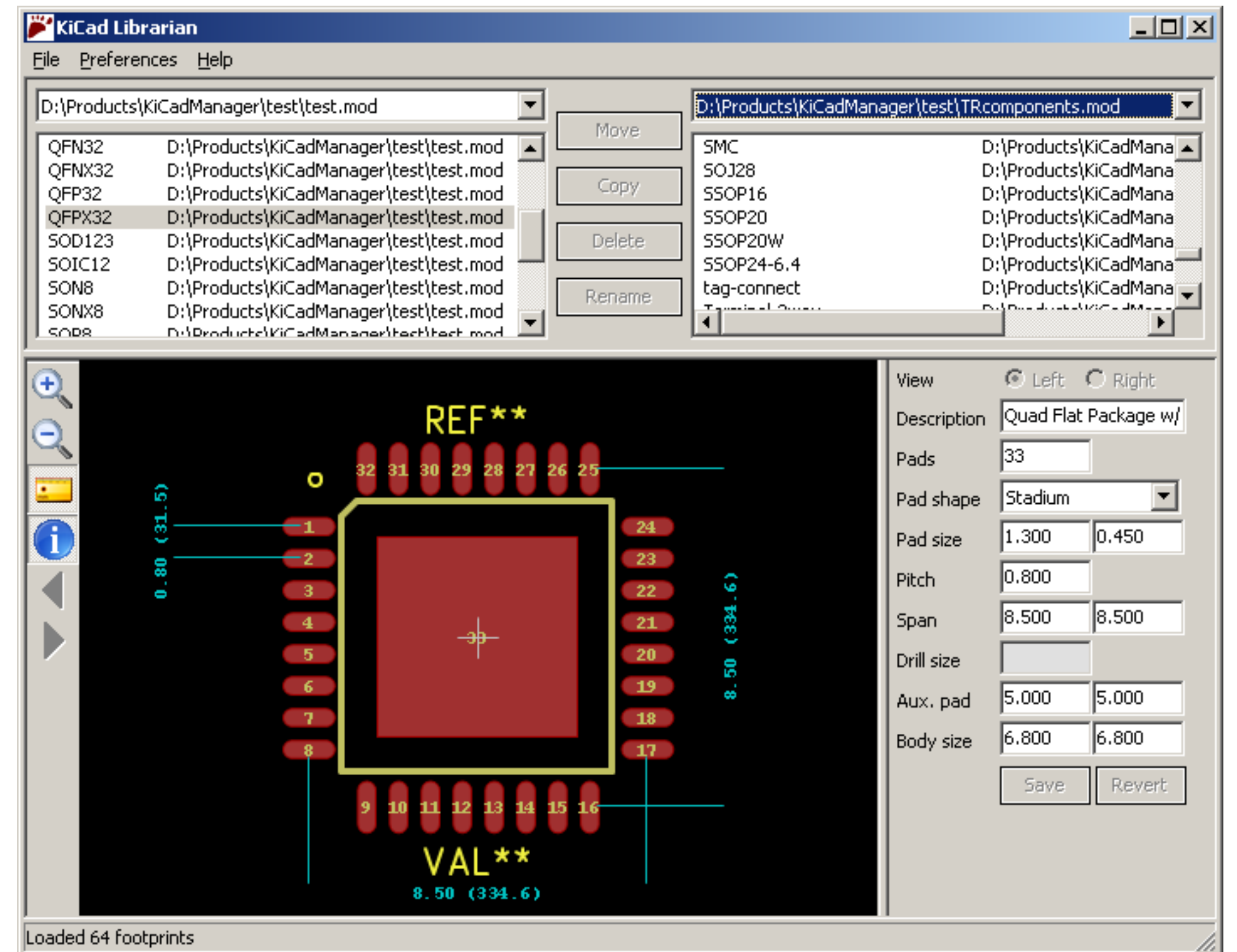

PCB封装库的来源

- CAD工具自带的标准库（安装选装或官网下载）
- 现有参考设计源图中提取
- 半导体原厂（TI、ADI等）设计文件下载
- 第三方网站下载 - Ultra Librarian、SamsacSys
- 自己创建

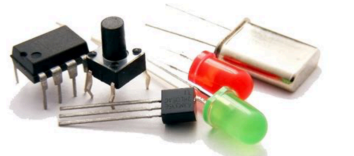

元器件封装库的构成三元素

- 焊盘 (形状、位置、编号)
- 外形轮廓
- 丝印标注
- 3D模型 (STEP)

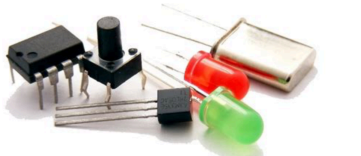
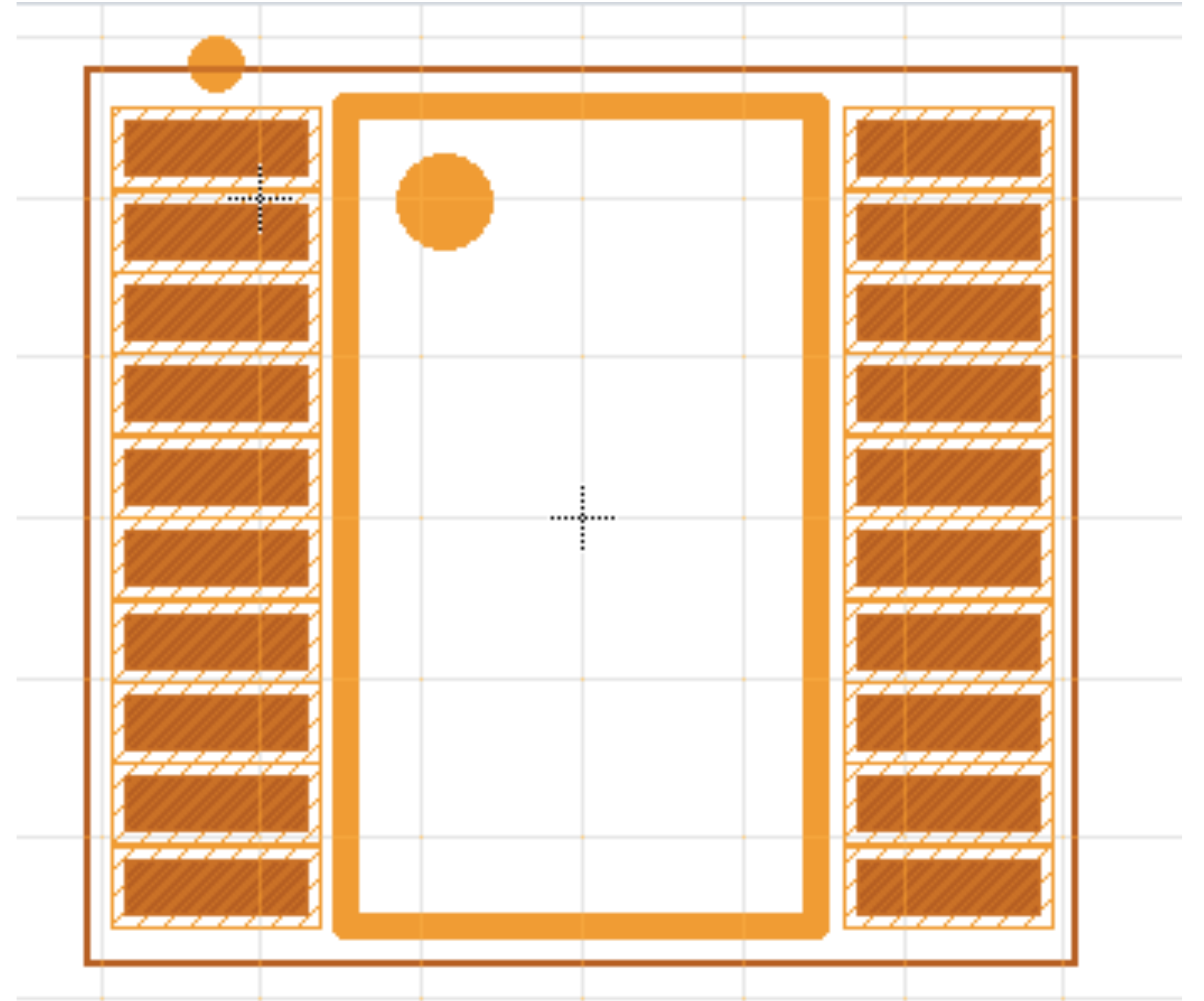

焊盘 - Pad/Land

- 选择焊盘类型 - 器件形状、大小、布置形式、振动、受热、受力等因素
- 泪滴状焊盘 - 发热且受力较大、电流较大
- 各元件焊盘孔的大小要按照元件引脚粗细分别编辑确定
- 注意焊盘和焊盘中心间距是否与器件管脚中心间距一致

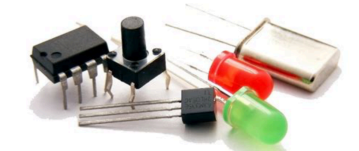
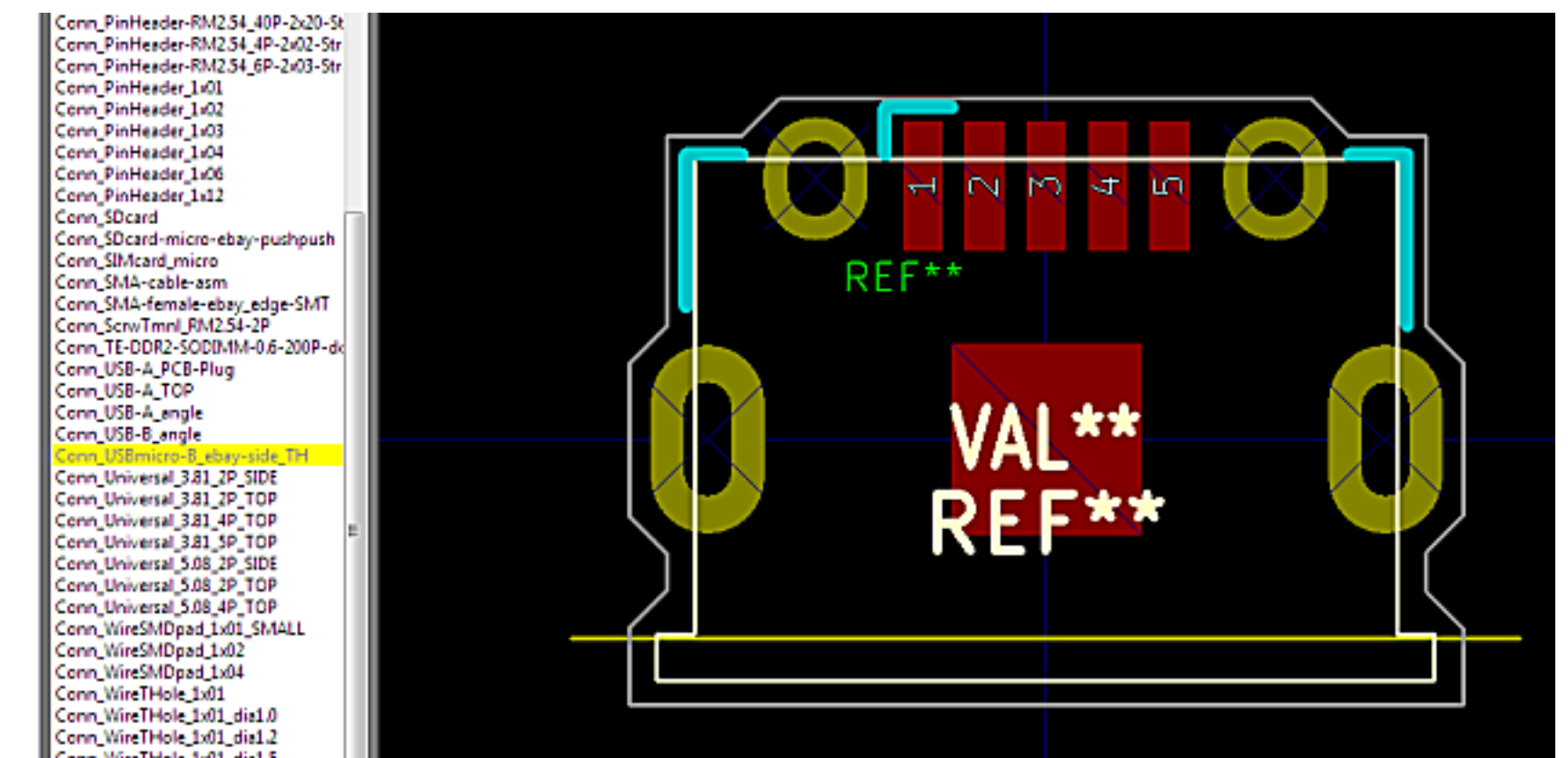
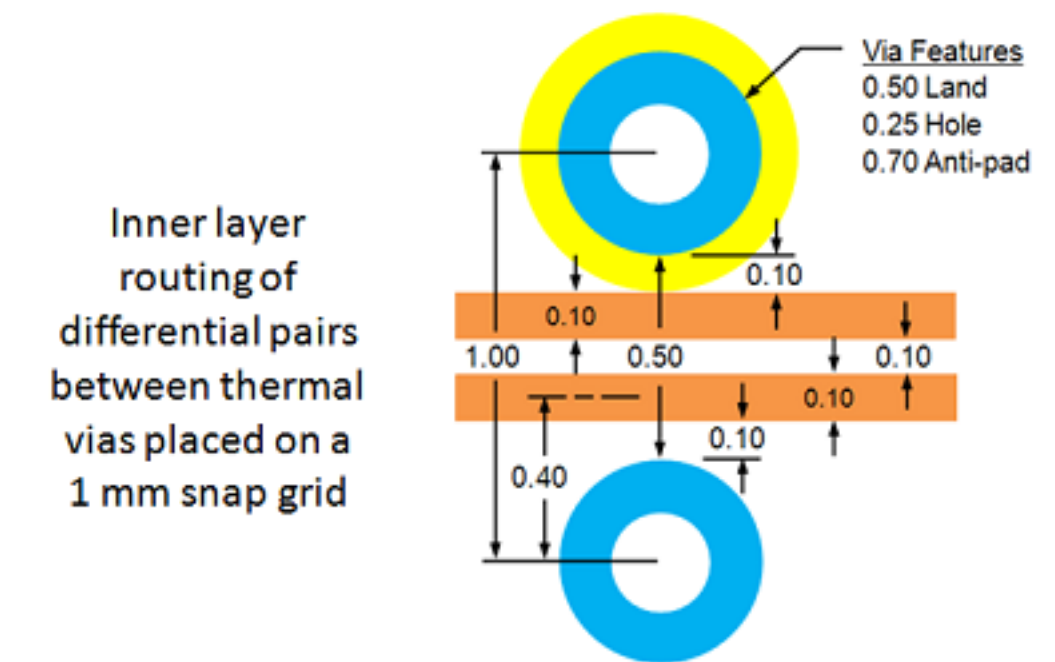
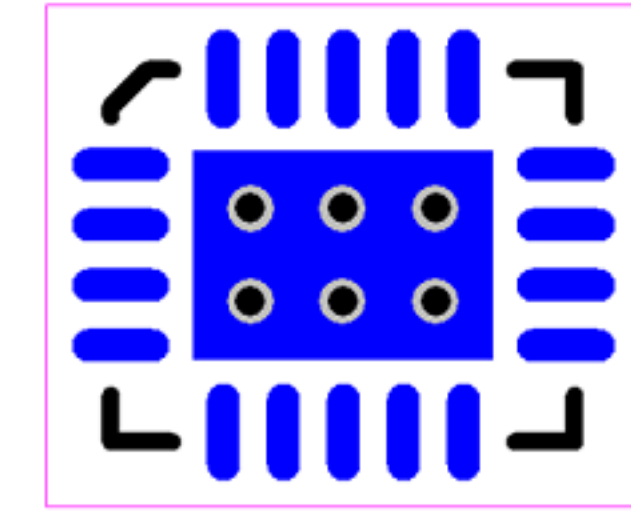
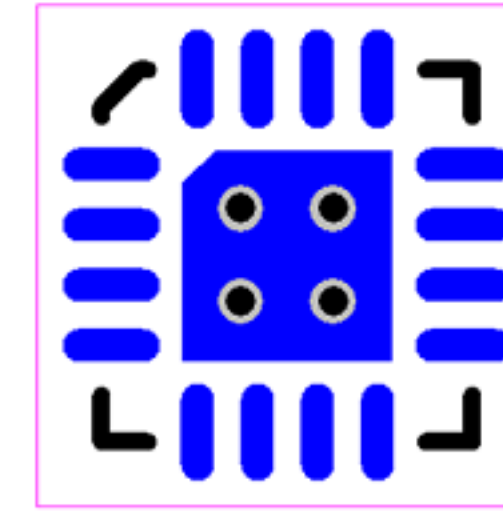

外形轮廓 - 元器件不能冲突，尤其是焊接、安装

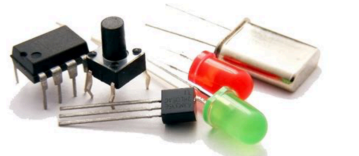
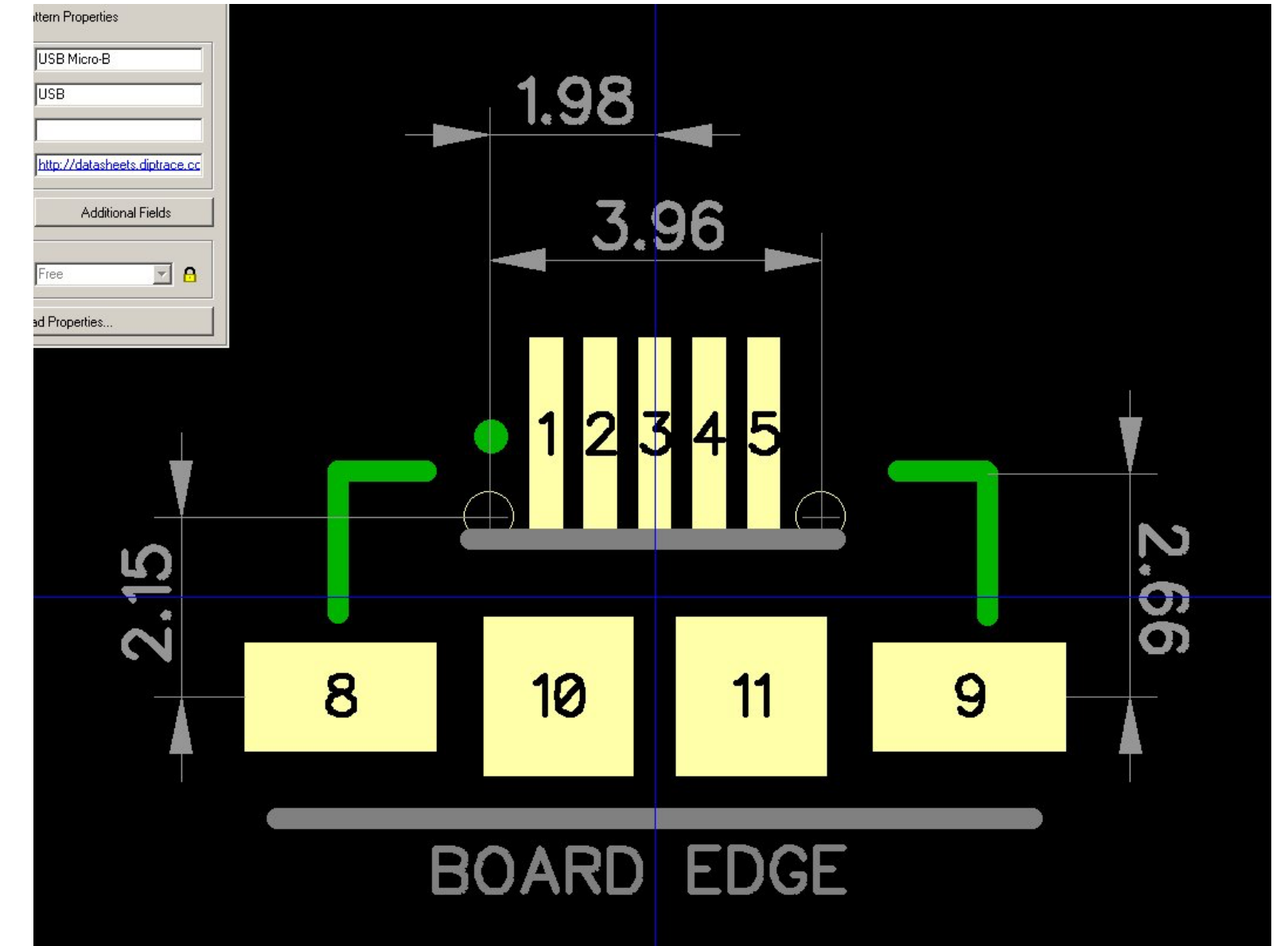
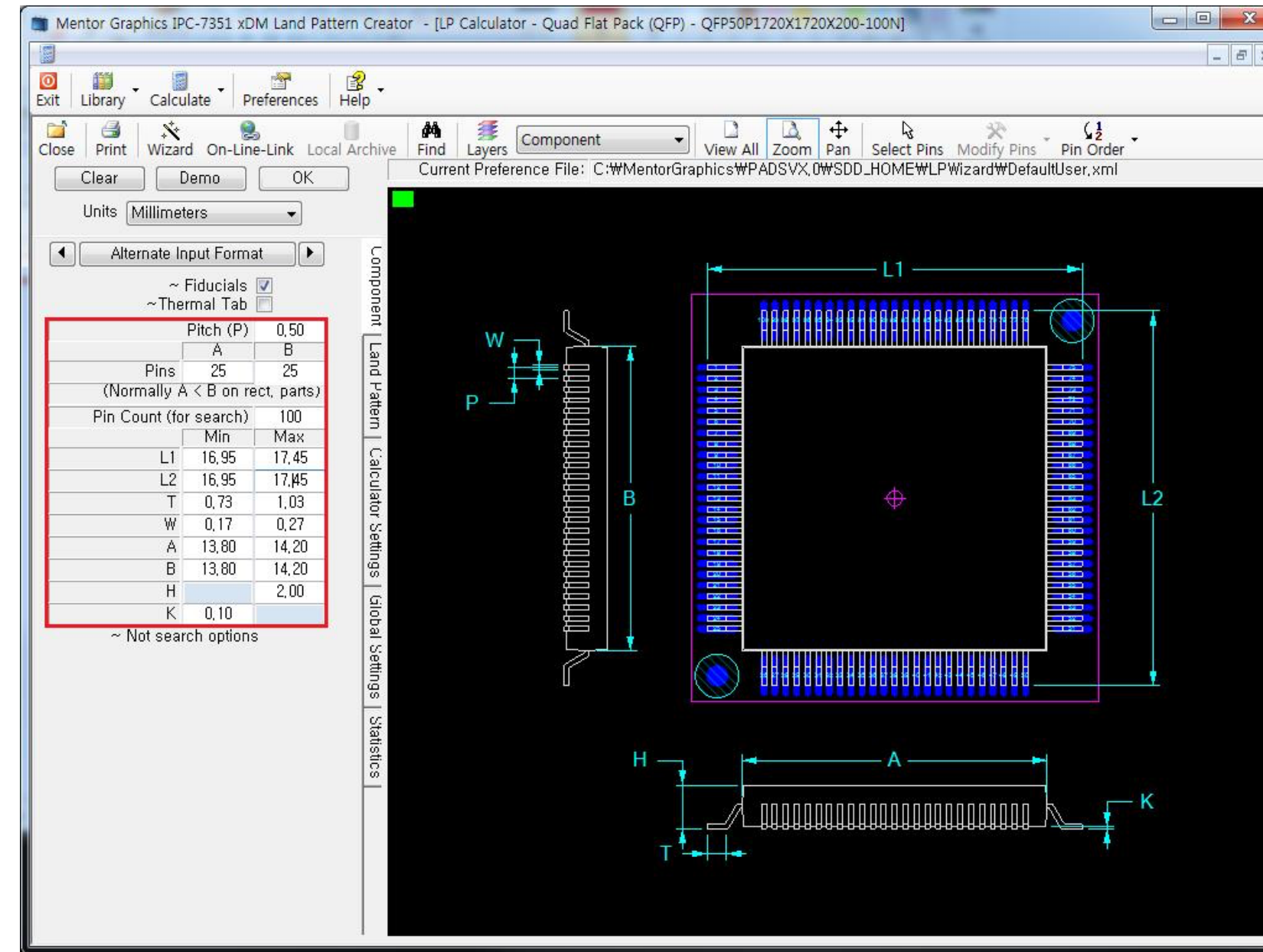
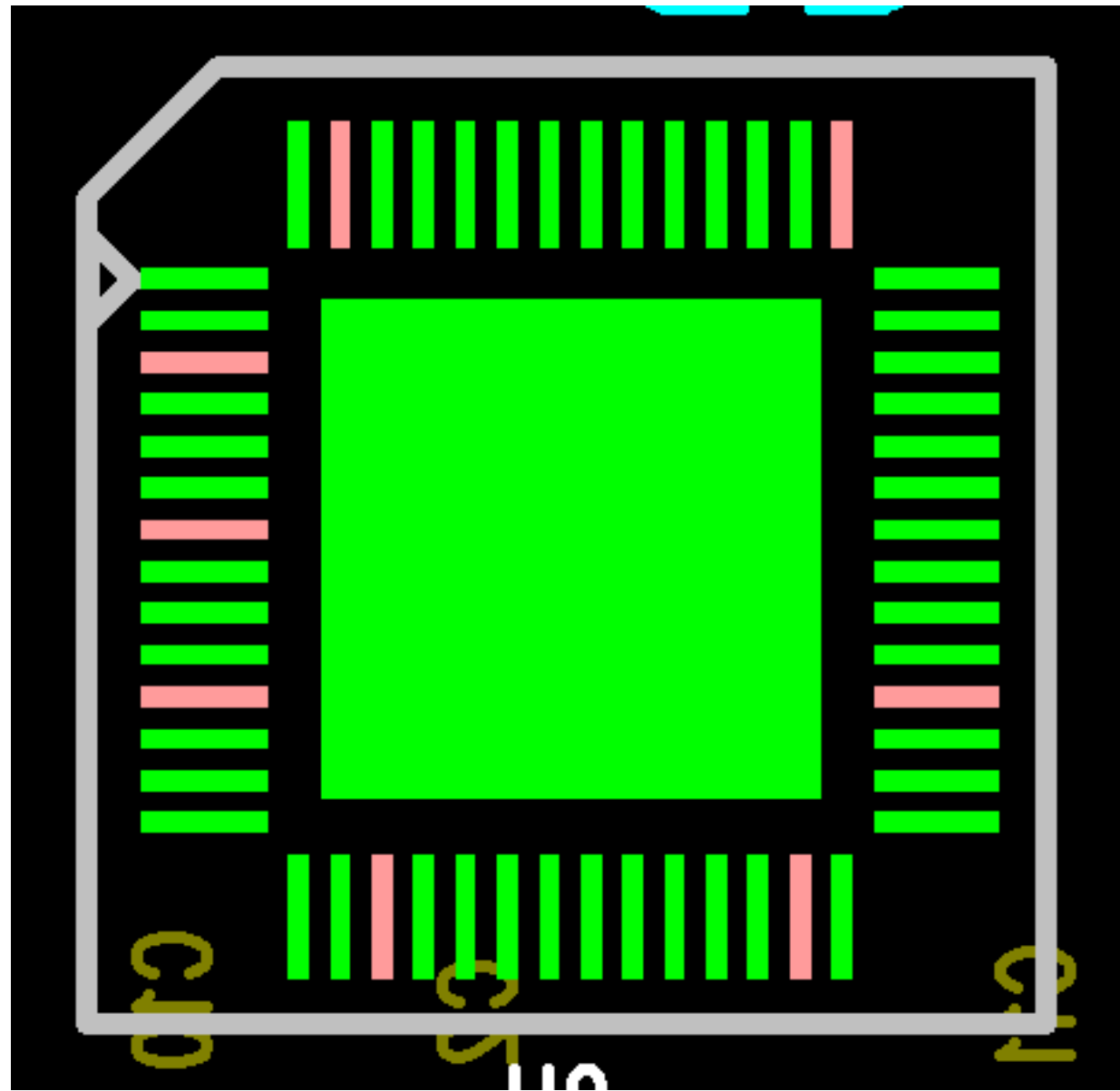

焊盘大小：管脚焊盘宽度同数据手册中一致或略宽

管脚长度略长于数据手册中器件的管脚长度

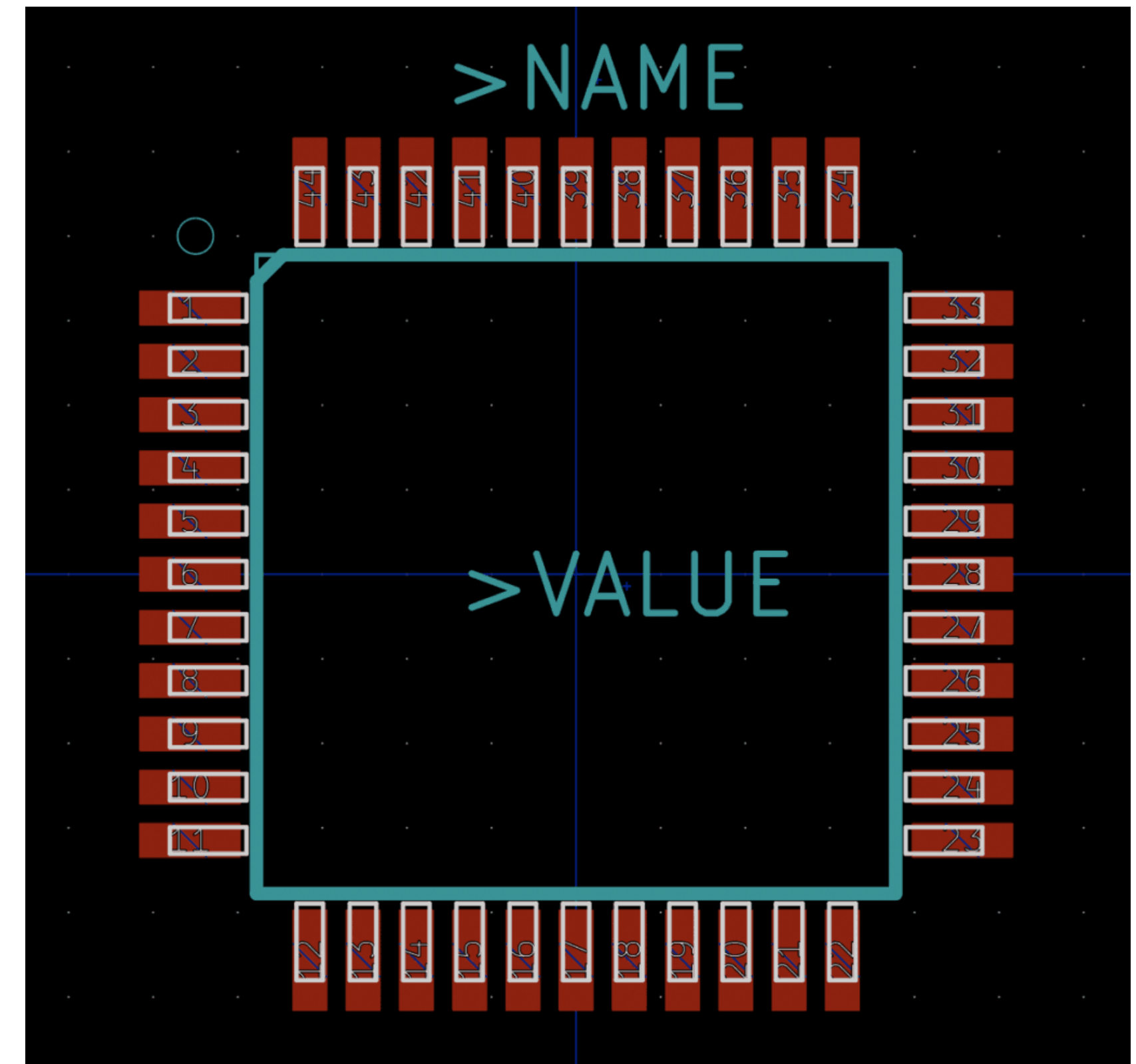
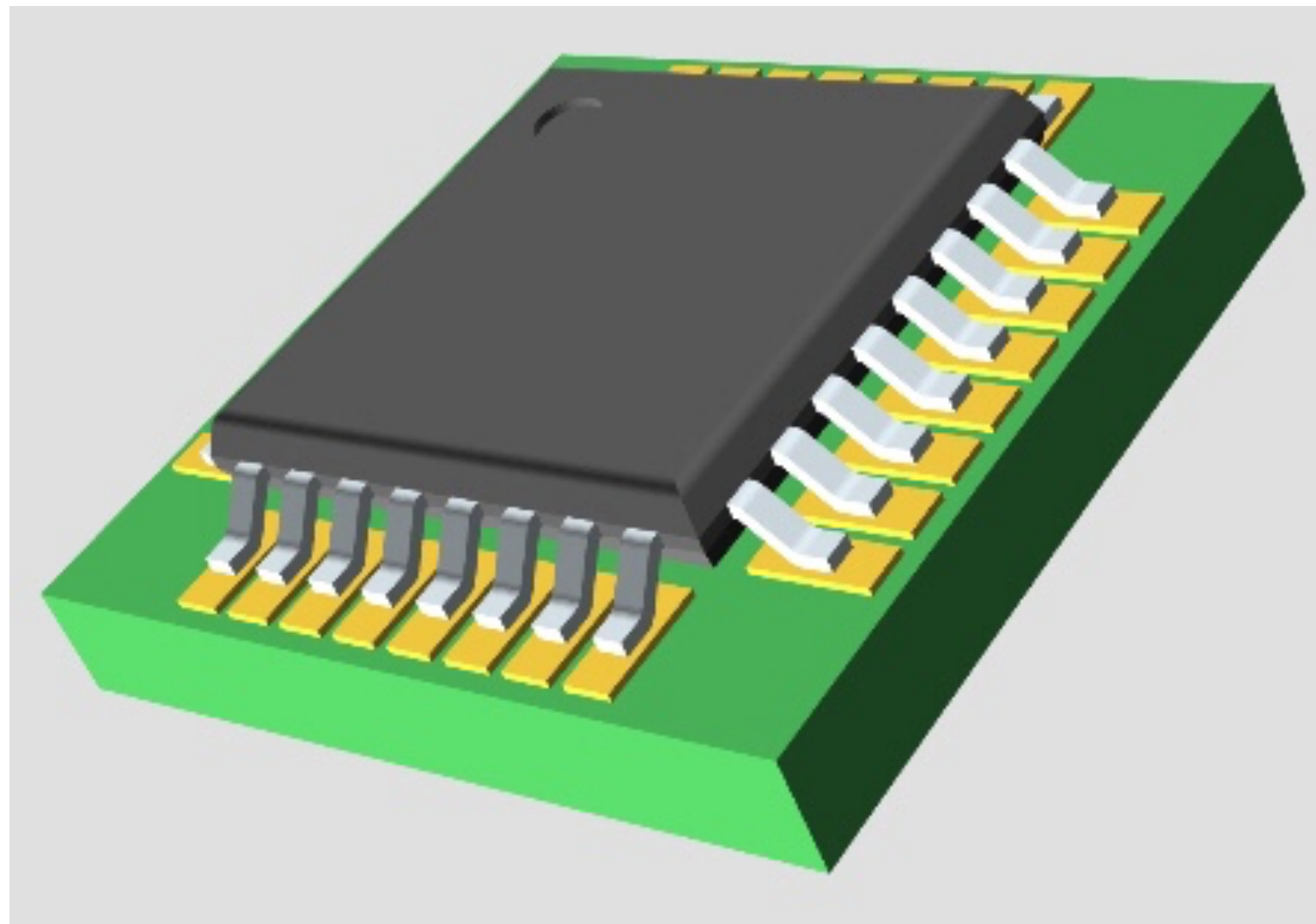

封装库和原理图符号库的管脚编号要对应并有丝印标记

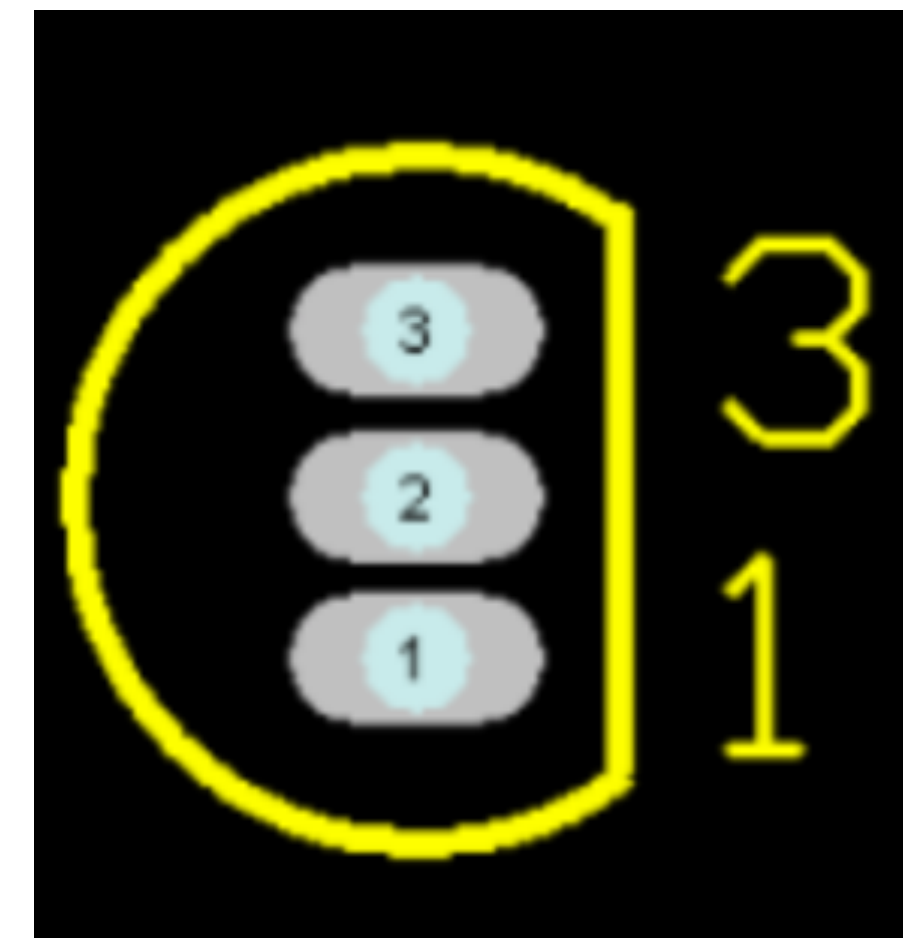
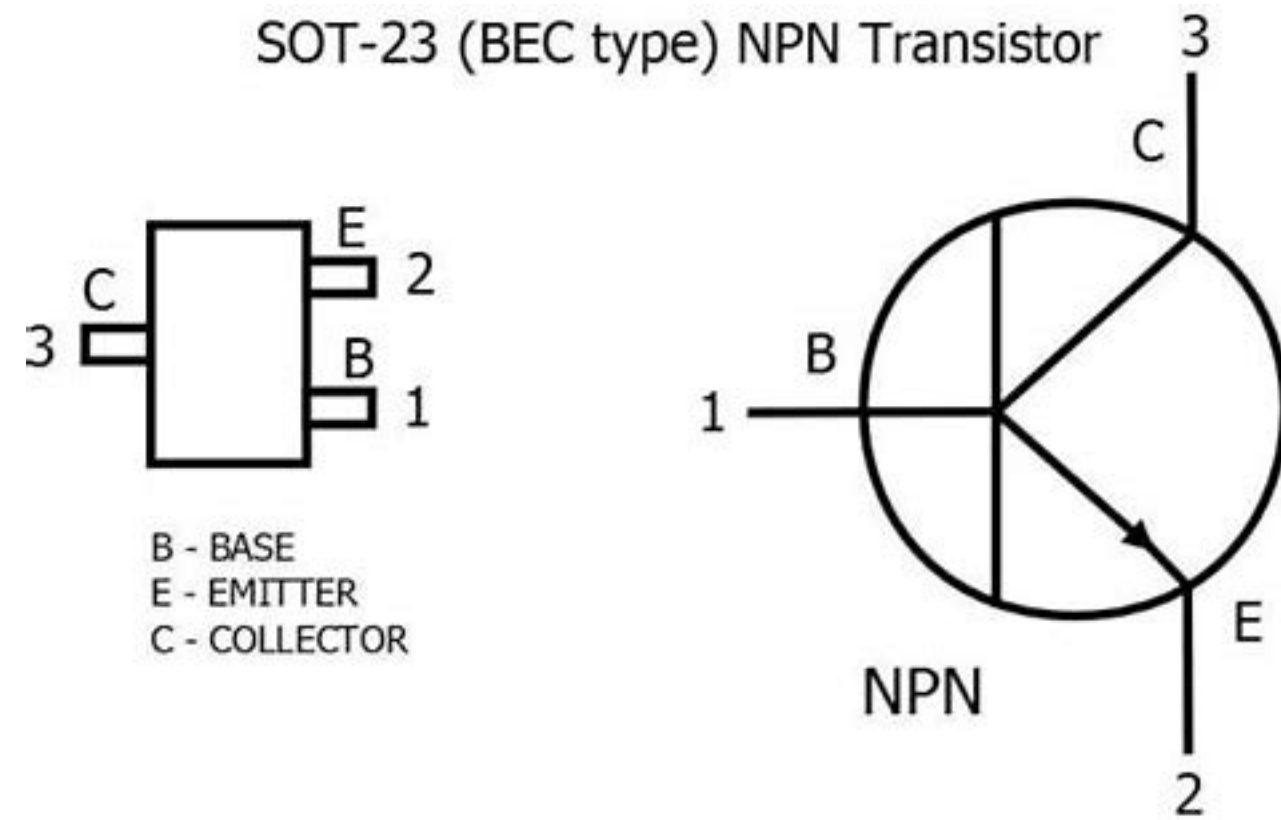
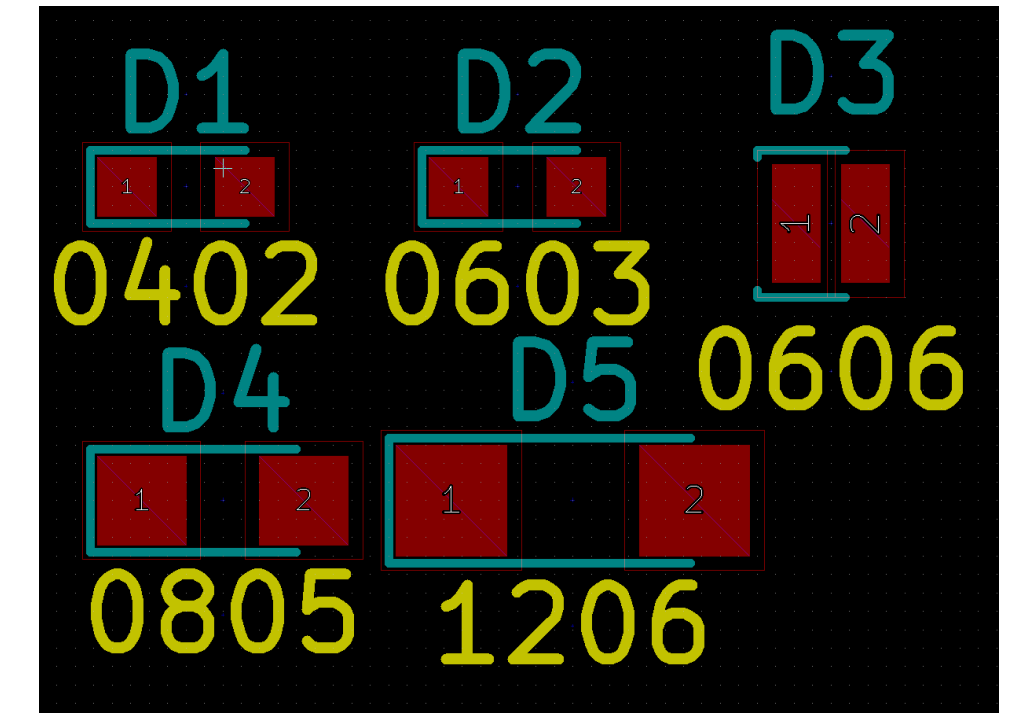
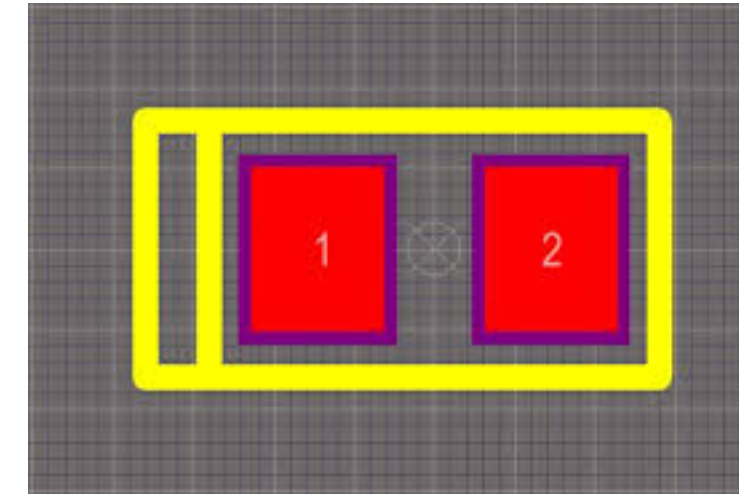
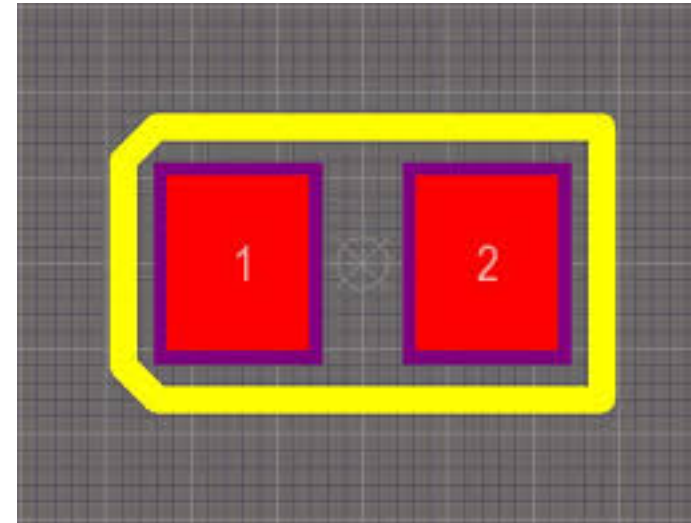
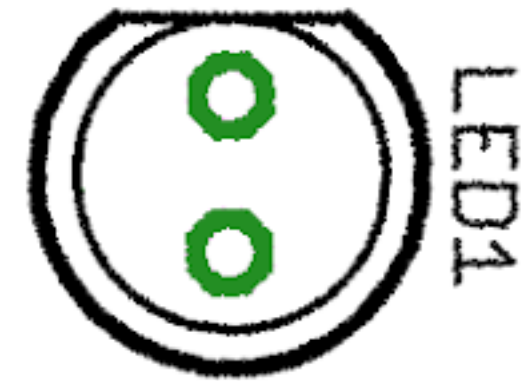
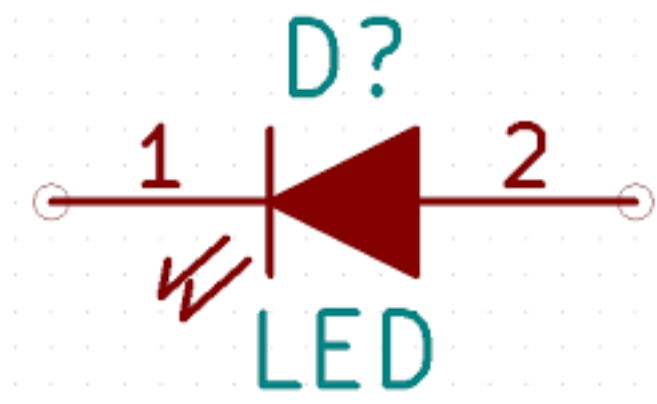

通孔的器件封装库 - 注意管脚的粗细和形状

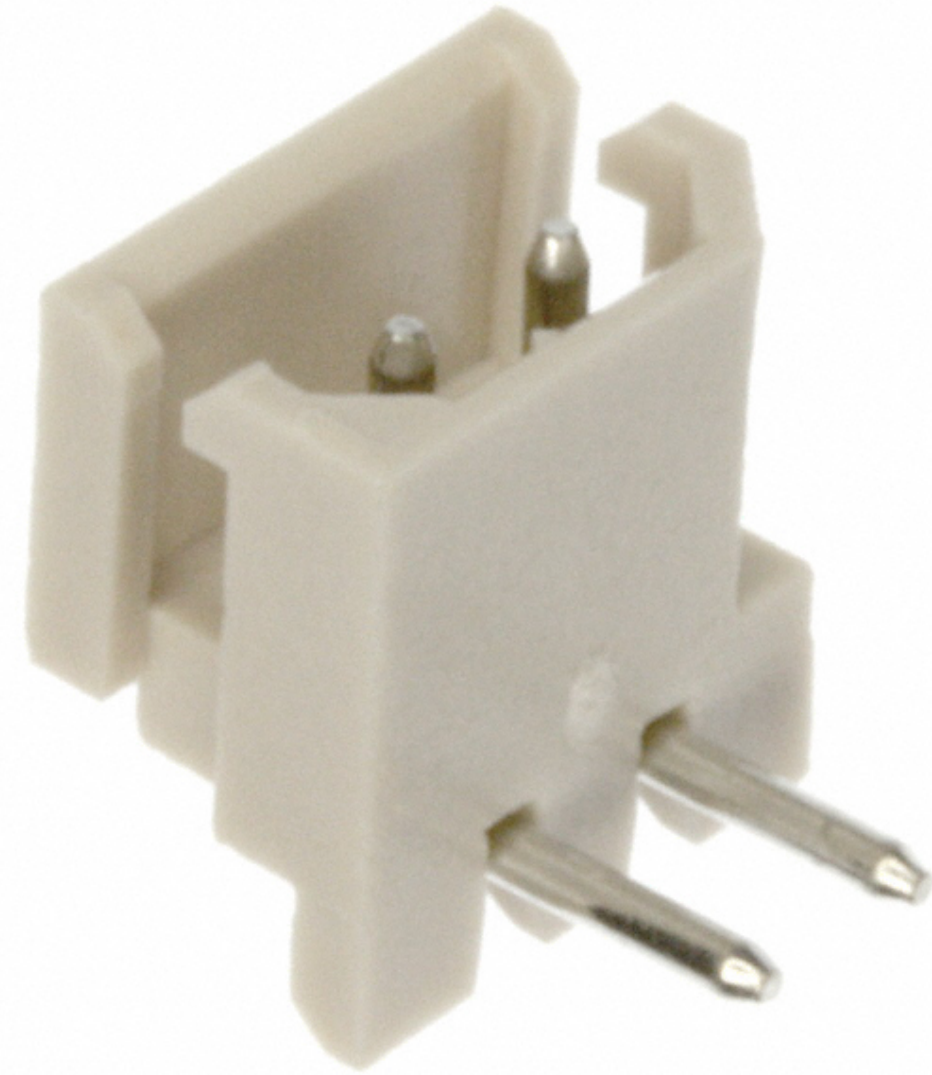

注意定位用的管脚 - 位置、编号、孔径、接地与否?

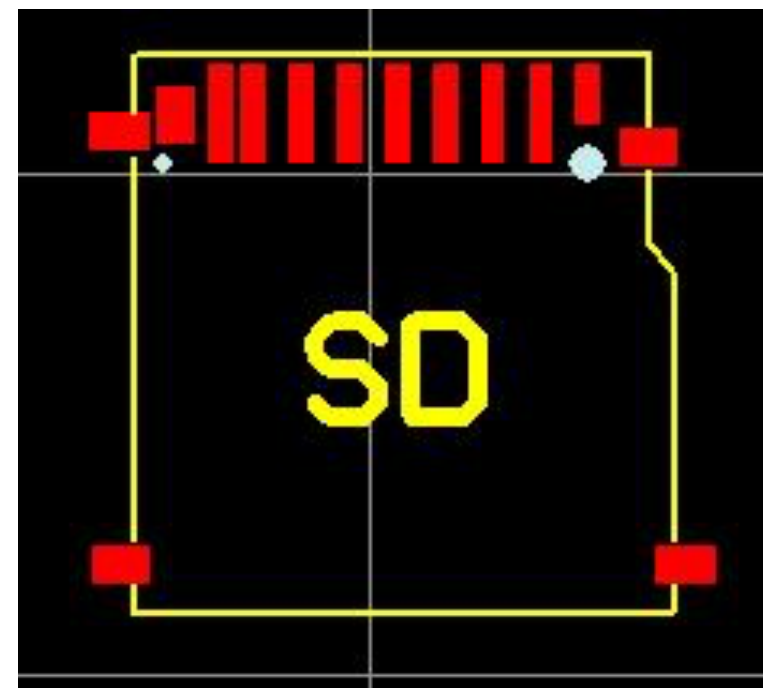
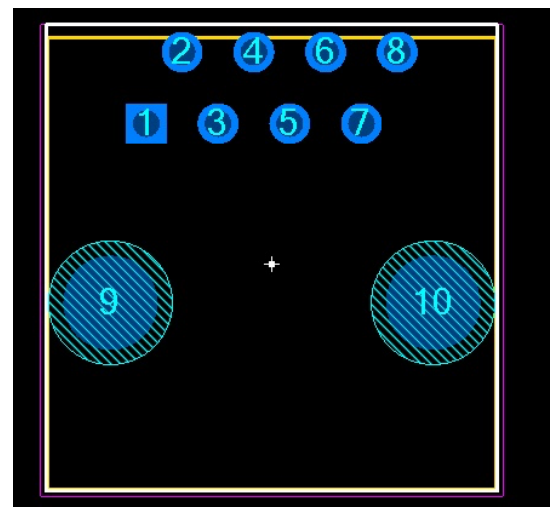
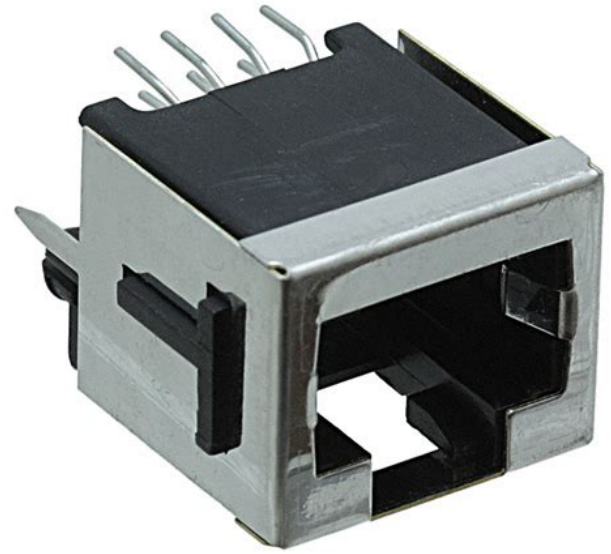

GCT

USB3135-30-A

USB3100 Series 5 Pin SMT Right Angle Top Mount Micro USB Receptacle w/ Peg

Availability: **In Stock**
Package Type: **N/A (Add Suggestion)**
Average Price: **\$0.39 USD**
CAD Models: **Symbol and Footprint**

[Add to Library](#)
[See Datasheet PDF](#)
[Buy Component](#)

Symbol and Footprint Library /

2D Model 3D Model

GCT Approved by GCT

Symbol

Footprint (Unlink Footprint)

USB3135-XX-X_REVB 0

[Download Symbol and Footprint](#)
Downloaded 2 times

GCT_USB3135-XX-X_REVB 0

[Download Footprint](#)
Downloaded 3 times

设定好原点

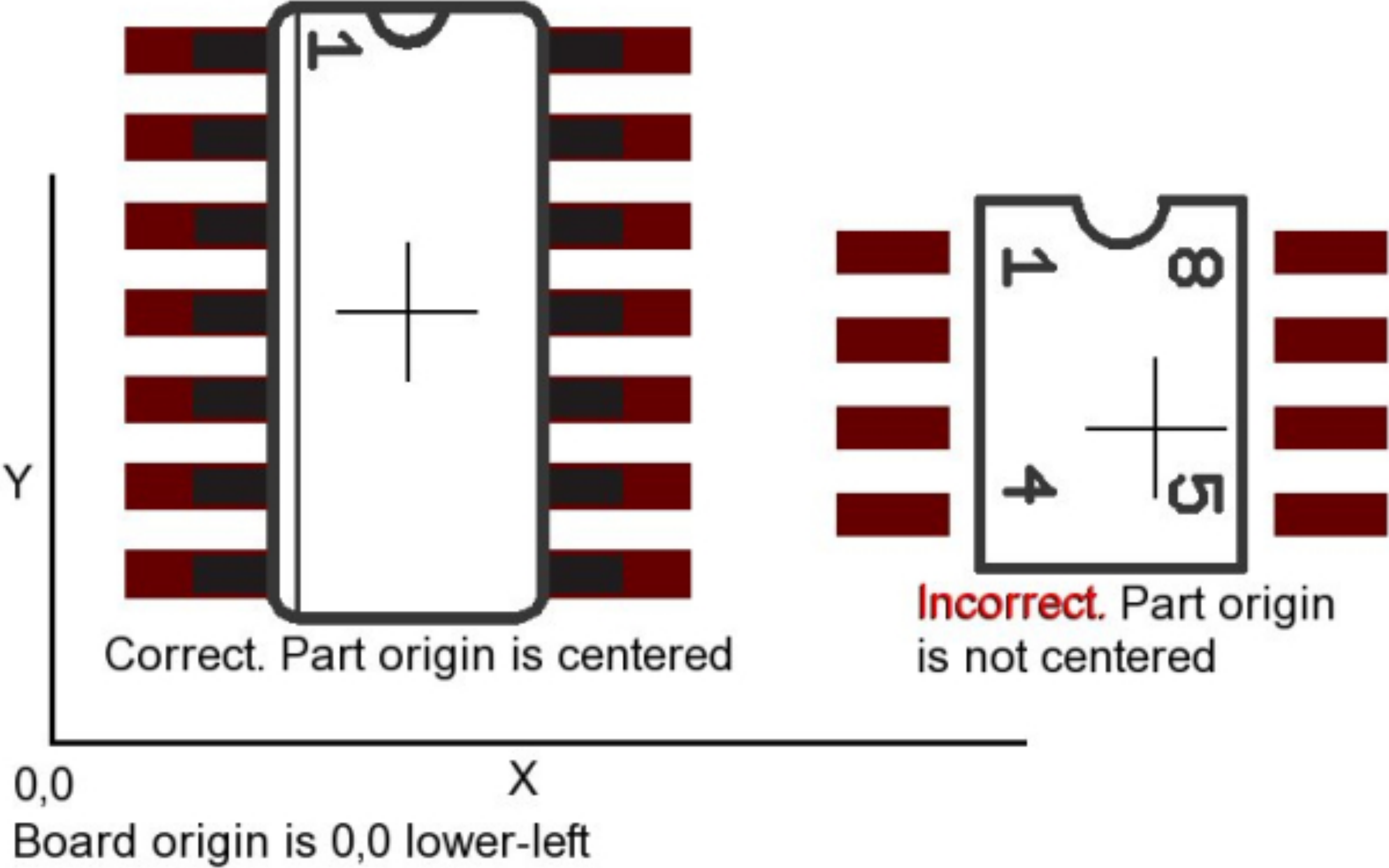

明确、正确的丝印标注

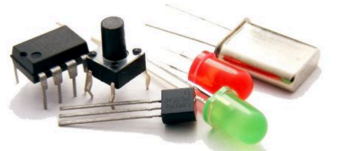
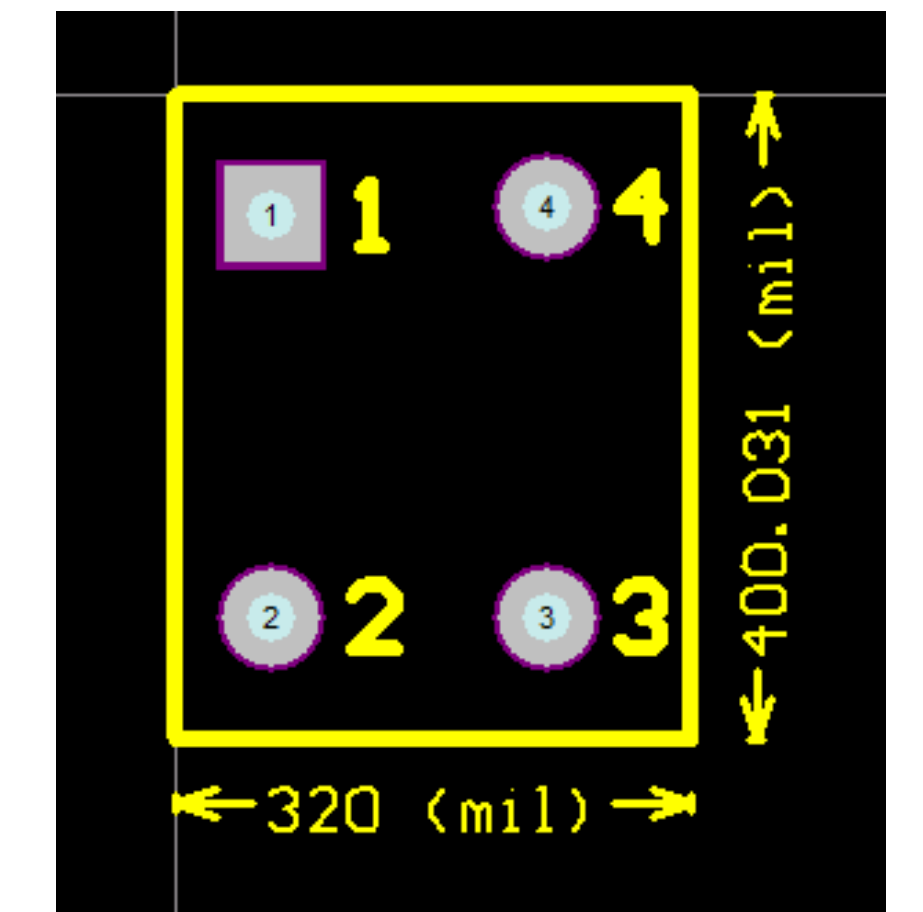
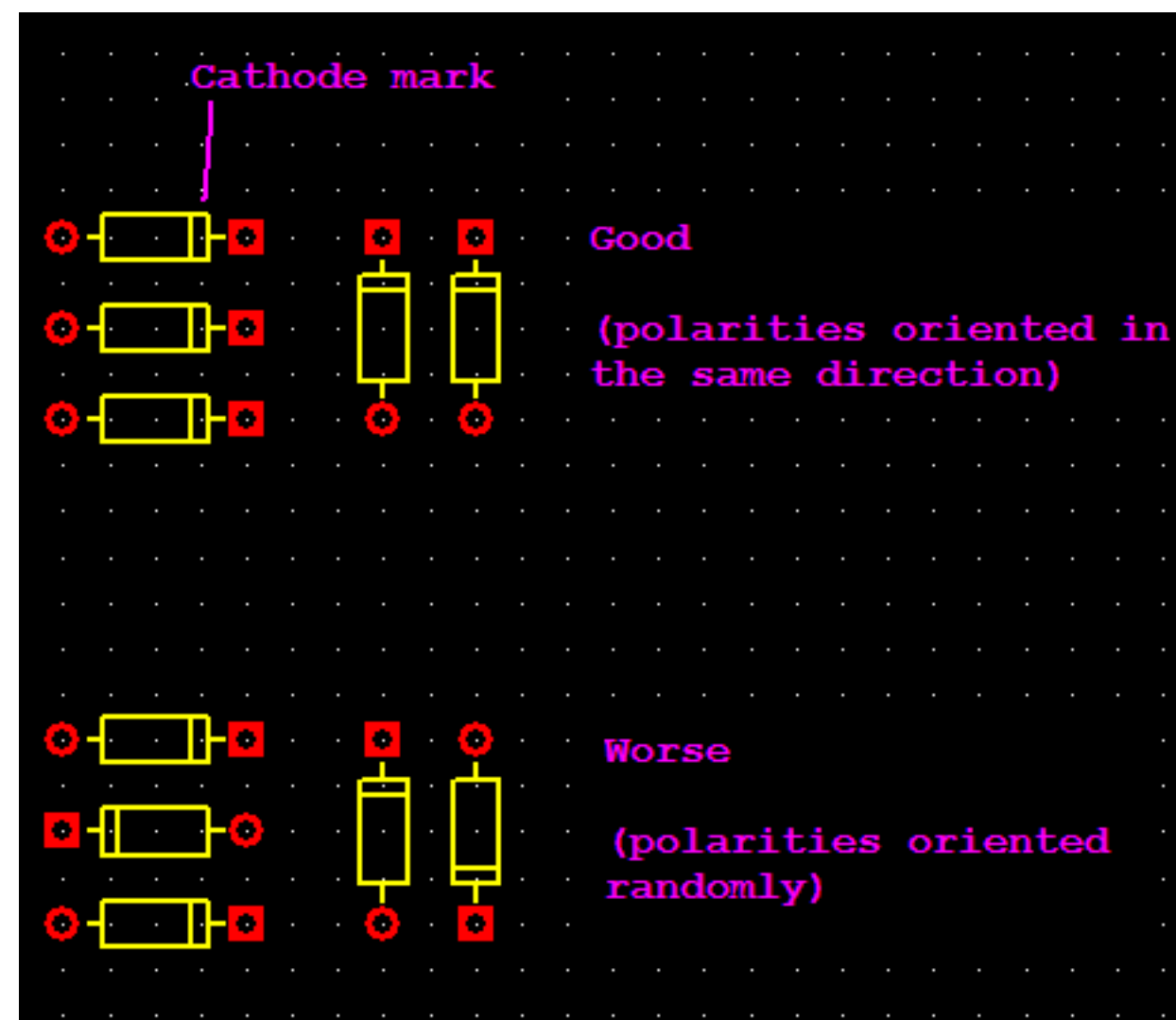
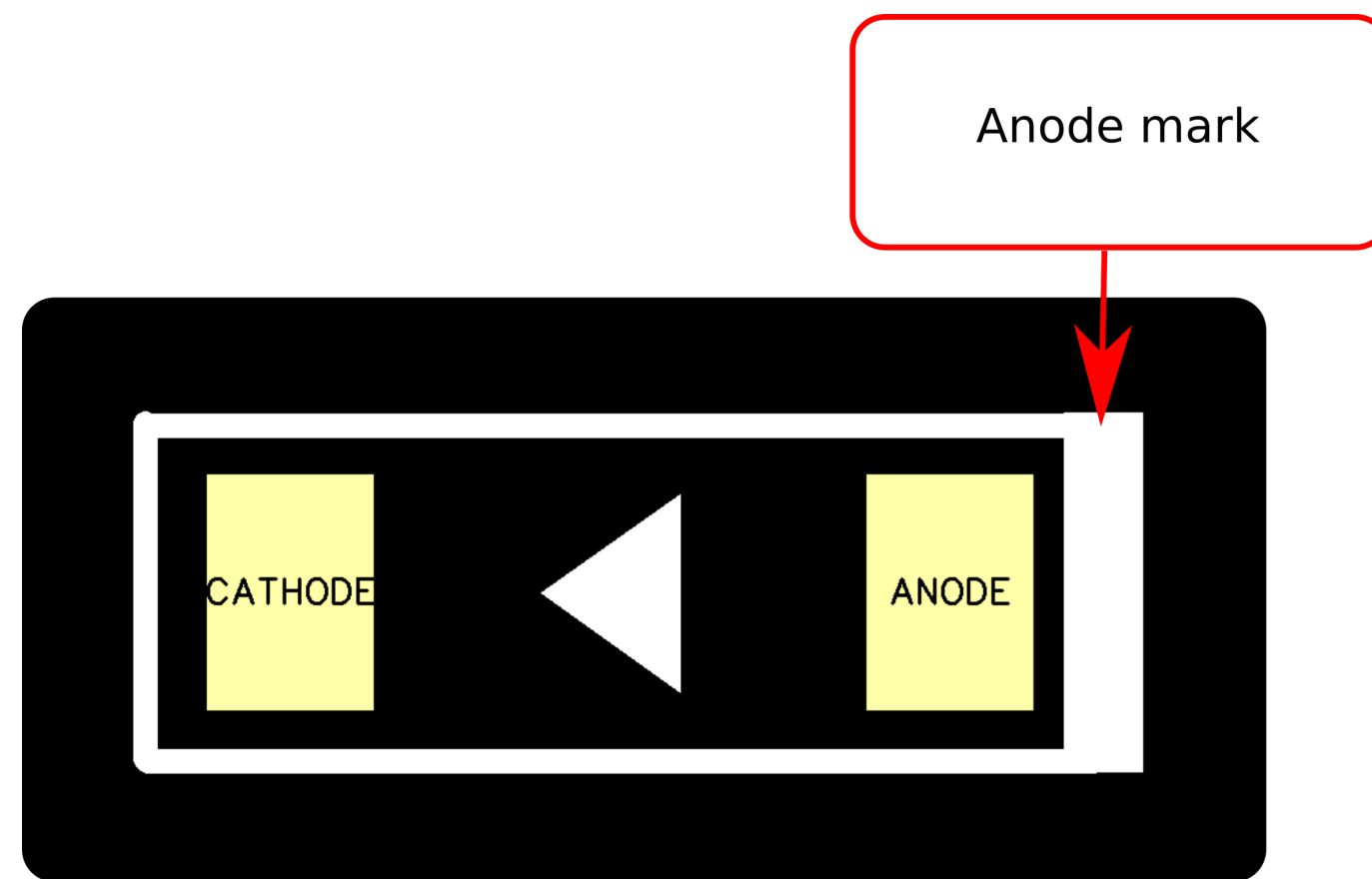
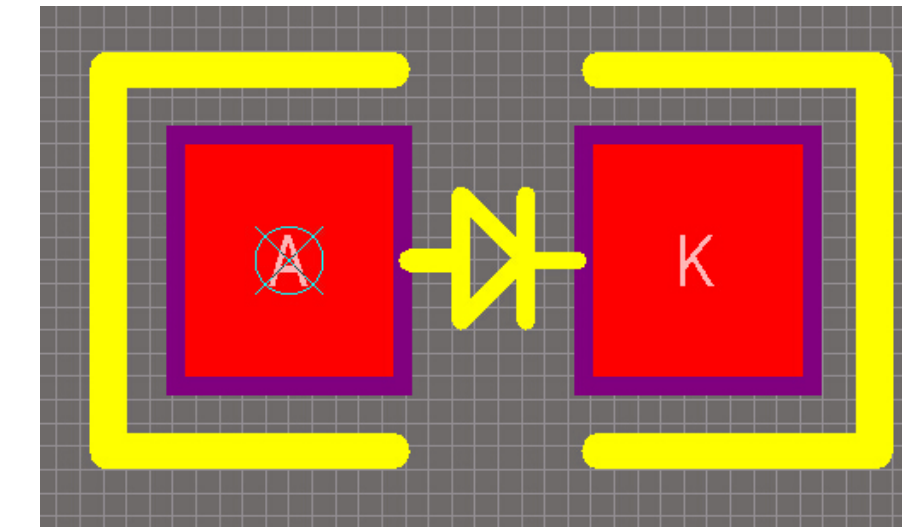
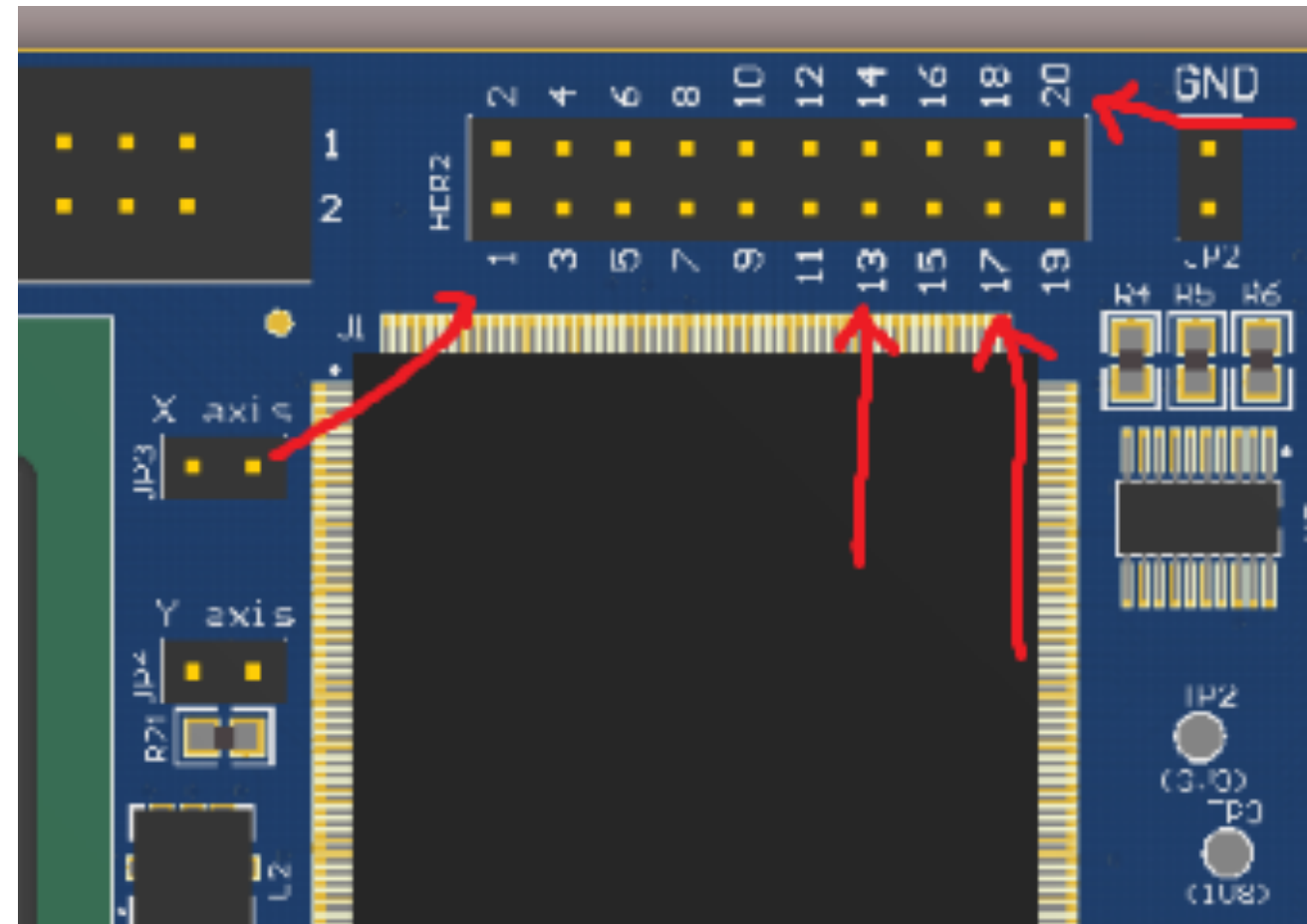
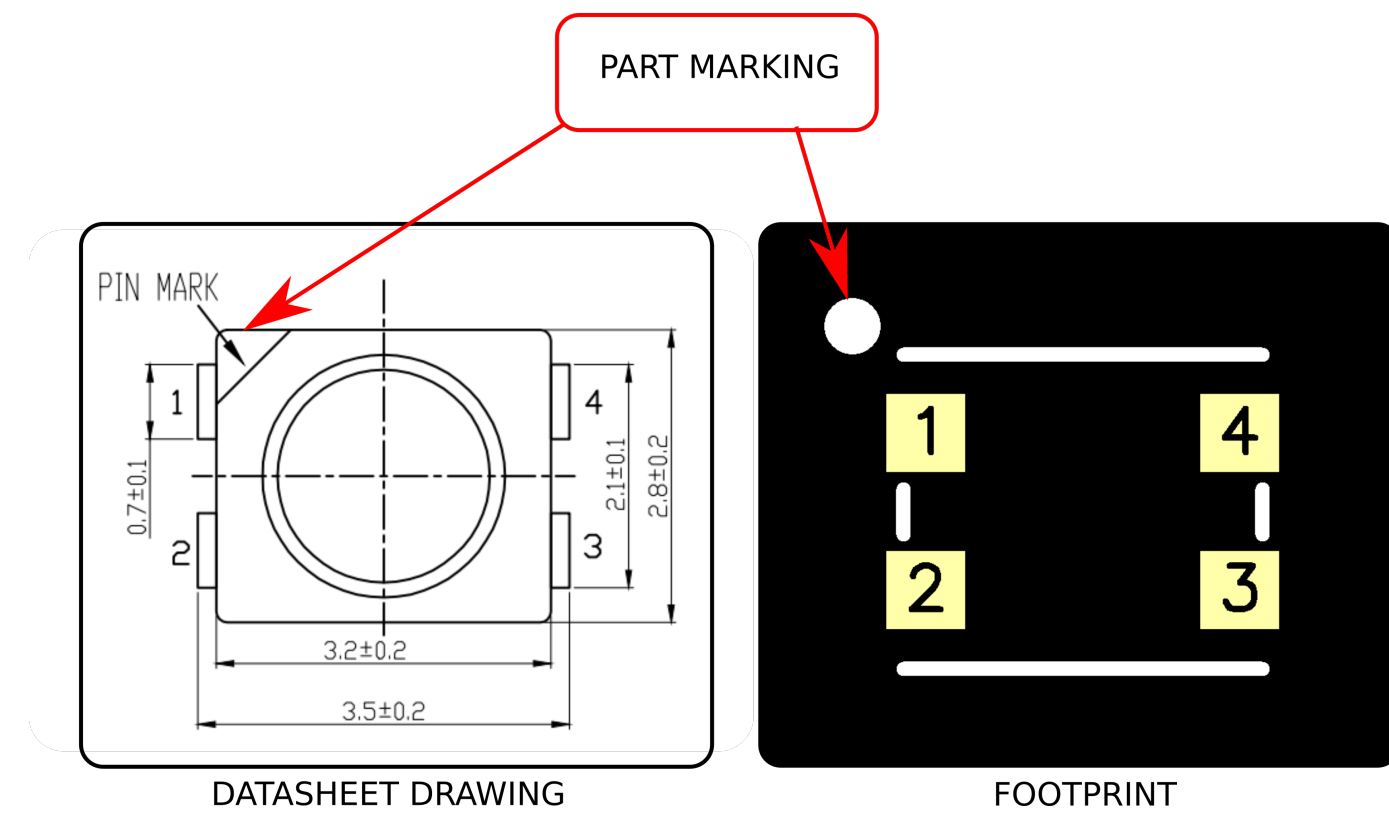

打印同实物进行对比验证

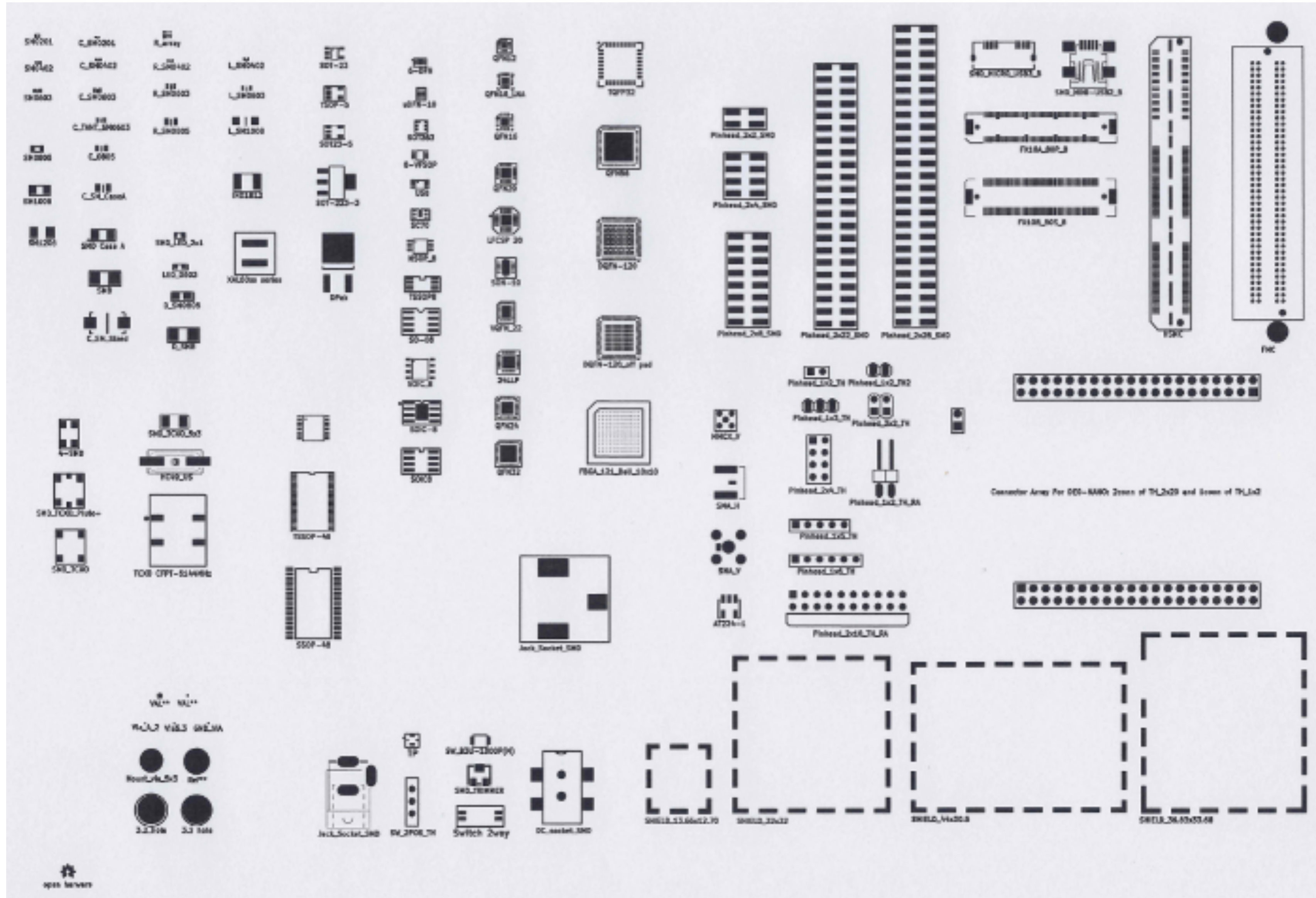

关于贸泽电子 - www.mouser.cn

The screenshot shows the Mouser Electronics website interface. At the top, a blue banner features the slogan '在MOUSER 采购很EASY!' and three key benefits: '数百万产品 一站式购齐', '接受微信支付 付款更简单', and '上海客服 本土支持'. Below this is a navigation bar with the Mouser logo, 'MOUSER ELECTRONICS', and links for '产品', '制造商', '更多', '订单历史', '登录', '注册', and a shopping cart icon. A search bar is located below the navigation bar, with filters for '全部', '物料编号/关键字', '有库存', and 'RoHS'. The main content area includes a '产品类别' sidebar with categories like 'LED照明', '工业自动化', '工具与供应', '工程工具', '无源元件', '内存和数据存储器', '电线与电缆', '电路保护', and '电源'. A central promotional banner advertises '额满免运费*' (Free shipping when order value reaches 175 yuan) and '关注贸泽微信 掌握最新资讯' (Follow Mouser WeChat for the latest news). At the bottom, there is a '最新产品' (New Products) section featuring logos for Texas Instruments, Infineon, Intel, and Molex.

- 与非网/摩尔吧多年合作伙伴
- 全球领先的电子元器件授权分销商
- 700家原厂/500万现货库存
- 小批量采购，170元免邮费
- 1-2周交货

